



# NMEA Autoswitch

## NSW-1-B

### User Manual

Issue 1.30

- Automatic source prioritisation interface for use with the NMEA 0183 standard. Automatic selection of one NMEA data source from multiple marine electronic devices / instruments
- Personal computer (RS232) interface to NMEA 0183 standards



# Contents

<b>Important Notices</b>	<b>4</b>
<b>Notices</b>	<b>4</b>
<b>Foreword</b>	<b>4</b>
<b>Introduction</b>	<b>4</b>
<b>General features</b>	<b>5</b>
4 NMEA 0183 data input ports	5
An NMEA 0183 autoswitched data output port	5
A PC compatible RS-232 bi-directional port	5
<b>Technical features</b>	<b>5</b>
<b>Software updates</b>	<b>5</b>
<b>Connecting devices together</b>	<b>6</b>
The basics	6
The NMEA signals	6
The different NMEA standards	6
<b>Connections</b>	<b>7</b>
<b>Connecting to NMEA devices</b>	<b>8</b>
NMEA 0183 Inputs	8
NMEA 0183 Output	8
<b>Other Connections</b>	<b>9</b>
Connecting to a Personal Computer	9
Connecting to the battery supply	9
<b>Troubleshooting guide</b>	<b>10</b>
Diagnostic LED	10
<b>Specifications</b>	<b>11</b>
<b>Company Information</b>	<b>12</b>

## Important Notices

The **Actisense™** NMEA Autoswitch (NSW-1) is intended for use in a marine environment, primarily for below deck use. If the NMEA Autoswitch (NSW-1) is to be used in a more severe environment, such use may be considered misuse under the seller's warranty.

The **Actisense™** NMEA Autoswitch (NSW-1) has been certified to comply with the European directive for Electro-Magnetic Compatibility (EN60945), and is appropriately CE marked. Operation of the unit should be in conjunction with appropriate CE approved shielded connectors and cabling used in accordance with the CE directive EN60945. Any EMC related issues should be reported to Active Research immediately to allow the company to rectify or resolve EMC related problems in accordance with its obligations under EN60945.

If the unit is connected such that compliance failure occurs beyond the company's control, the company shall not be held responsible for compliance failure until suitable EMC guidelines for connection are seen to have been taken.

## Notices

When using this document, keep the following in mind:

The products described in this manual and the specifications thereof may be changed without prior notice. To obtain up-to-date information and/or specifications, contact Active Research Limited or visit the **Actisense™** website ([www.actisense.com](http://www.actisense.com)).

Active Research Limited will not be liable for infringement of copyright, industrial property right, or other rights of a third party caused by the use of information or drawings described in this manual.

All rights are reserved: The contents of this manual may not be transferred or copied without the expressed written permission of Active Research Limited.

Active Research Limited will not be held responsible for any damage to the user that may result from accidents or any other reasons during operation of the user's unit according to this document.

As part of the autoswitch algorithm, the NSW-1 does validate the NMEA sentence checksum and deletes/blocks any sentences that fail this check. In addition, the NSW-1 also reads specific status indicators within particular NMEA sentences in order to validate the input data stream as a whole. However, the electronic device(s) supplying the NSW-1 with NMEA data retain(s) the sole responsibility for the NMEA data's validity.

## Foreword

**Actisense™** recognises that instructions are often skipped, so we have aimed to write this document in an informative, yet direct manner that will aid the user. We have tried to cover all the points a typical user may need to know. Please read all sections before installing and using the **Actisense™** NMEA Autoswitch product and any related software programs.

## Introduction

The **Actisense™** NMEA Autoswitch (NSW-1) has been designed to automatically select the highest priority device from up to 4 connected input devices. This creates a system capable of automatically selecting the next priority device if the higher priority device fails for one of three reasons: a complete failure to send any NMEA data, an invalid NMEA sentence checksum, or if the validity flag(s) contained within the received NMEA sentence indicate that this data is not valid and should only be used with caution.

The unique **Actisense™** NMEA Autoswitch product has evolved out of the requirement to solve two fundamental problems with the existing marine industry NMEA 0183 communications standard.

The NMEA 0183 standard allows any suitably designed marine electronic device to share its gathered information with any other device on a vessel. Unfortunately, there is one very large drawback with this standard - only one device on a connected network can actually send data (a single talker), with multiple devices (determined by the current limit of the sending unit) listening to that data (multiple listeners).

Secondly, for systems that have multiple NMEA devices of an **identical** type (e.g. two GPS's or two depth sounders), automatic selection of the highest priority device is normally a vital requirement. However, the NMEA 0183 standard has no method of automatically switching between different devices, so this requirement is usually fulfilled with a manual changeover switch: not a very good solution, but the only one available until now.

The **Actisense™** NMEA Autoswitch solves both of these problems by allowing up to 4 input devices/talkers, connected through galvanic opto-isolated inputs, to be analysed and the highest priority device's NMEA data always switched to a single output.

Full information on the complete **Actisense™** product range can be found on the **Actisense™** website.

## General features

### 4 NMEA 0183 data input ports

Each NMEA 0183 input port has a priority level. This is fixed to the logical order that matches the port numbers, i.e. port 1 has the highest priority and port 4 has the lowest.

### An NMEA 0183 autoswitched data output port

This output port has the automatically switched NMEA data from the highest priority input port currently receiving valid NMEA data.

The NSW-1 autoswitch contains special algorithms to control the selection of the highest priority input port:

1. The input port has to be receiving NMEA data.
2. The received NMEA data has to pass the NMEA sentence checksum test - failure of this test indicates that there has been interference and/or loss of signal in the reception of the data.
3. Any status flags contained within the NMEA data have to be of a valid nature. An invalid flag indicates that the data should only be used if no other data is available, and then only with caution. The device used to display this NMEA data will determine how to show/indicate the caution status of the NMEA data.

### A PC compatible RS-232 bi-directional port

This output contains the same data as the NMEA 0183 autoswitched output, only using the Baud rate of 38400.

## Technical features

**High-speed micro-controller** capable of 10 million instructions per second.

**Flash ROM technology** that supports automatic programming for quick and easy updates, 10,000+ erase cycles and a 10-year Data Retention provides carefree user configuration.

**On-chip memory store** allows buffering of short term NMEA data, allowing the unit to smooth short-term peaks in the NMEA data flow.

**NMEA 0183 inputs** are opto-isolated differential inputs to fully comply with the NMEA 0183 standard specification. This allows the inputs to work correctly with long cable runs and in a noisy environment. Typical operating voltage is 2.0v to 15.0v. Typical operating voltage is 2.0v to 15.0v. The unit can withstand +/- 35v continuously, and +/- 40v transients. The Opto-isolator can protect any upstream equipment (chart plotter, laptop PC, radar etc.) from up to 2000v of common mode voltage difference.

**NMEA 0183 full-differential output driver.** This can drive up to 15 fully compliant NMEA 0183 device loads, with a

30mA (maximum) drive capability. The full-differential output ensures better quality communications and lower noise emissions on unshielded twisted pair cabling.

**Full specification RS232 interface** ensures that any marine electronic device (or PC) that has an RS-232 port receives the autoswitched NMEA data. This connection also allows the unit to be updated via the free flash upgrade software that will be made available on the **Actisense™** website if the NSW-1 software has been enhanced.

**Wide battery input voltage range** to offer maximum compatibility, the NMEA 0183 Buffer NSW-1 can operate from a battery supply anywhere between 8 and 35 volts.

**Low Power Consumption** that is typically 26-30mA at 12 volts and 16-18mA at 24 volts.

**A diagnostic LED** indicates the operation mode of the NSW-1, if any faults have been detected, or the peak load currently on the highest priority valid NMEA input port.

**Very tough Polycarbonate case** is certified to IP66 (classified as "totally protected against dust and protection against low pressure jets of water from all directions"). Being Polycarbonate, it is also incredibly strong, offering a wide temperature range and superior protection to the electronics inside. The IP66 rating of the case is only limited by the sealing gasket strip, which can be enhanced by applying a suitable non-acid based marine sealant to the gasket after wiring and testing. This will allow use of the unit in areas where salt spray could enter, accidental immersion may occur, or in environments where maximum long-term reliability is paramount.

**Robust ABS grommets** are certified to IP68 (classified as immersible for long periods without water ingress). Note that to achieve this level of water integrity all grommets must be occupied by round-section cables.

**Large range of possible cable diameters** of between 4.5 mm and 10 mm, single or multi-pair wire types can be easily accepted.

## Software updates

The NSW-1's built-in firmware is held in "flash" memory, allowing quick and easy upgrades using a simple Microsoft Windows (95/98/ME/NT/2000/XP) user interface program (Flash Centre) running on a connected PC.

It is our policy to provide these updates free on our website, [www.actisense.com](http://www.actisense.com), so that your autoswitch can become more sophisticated with time, and should there be any bugs reported in the software, they can be promptly fixed without the unit coming out of commission. This upgrade can be performed with the unit completely in-situ, via a PC connected to the RS232 port.

## Connecting devices together

### The basics

NMEA data is transmitted from an information source such as GPS, depth sounder, gyro compass etc. These data sending devices are called “**Talkers**”.

Equipment receiving this information such as a chart-plotter, radar or NMEA display is called a “**Listener**”.

Unfortunately, only one Talker can be connected on to a single NMEA 0183 system at any one time. Two or more Talkers are simply not possible because they are not synchronised to each other, and will attempt to ‘talk’ at the same time (over each other), resulting in corruption of the NMEA data, and potentially in disaster if valuable data such as navigation information is lost or corrupted so that it is incorrect and/or misleading.

**Actisense™** produces a range of products to solve all NMEA interfacing requirements.

Please visit the [Actisense™ website](#) for full details on these and other **Actisense™** interfacing, Depth sounding and Sonar products.

### The NMEA signals

The NMEA 0183 system v2.0 and later uses a “differential” signalling scheme, whereby two wires are used to transmit the NMEA data. These connections will be labelled as either NMEA “**A**” and “**B**” or NMEA “**+**” and “**-**” respectively, depending on the instrument and manufacturer.

When connecting between different manufacturers, there can be some confusion, but it is simple and easy to remember: NMEA “**A**” connects to NMEA “**+**” and NMEA “**B**” connects to NMEA “**-**”.

### The different NMEA standards

The NMEA 0183 specification has slowly evolved over the years, so connecting one device to another is not always a straight forward matter. The earlier versions of NMEA 0183 (before v2.0, as detailed above), used slightly different connection methods and signal levels: the instruments had just one “NMEA” data line (‘**Tx**’ or ‘**Out**’), and used the ground as the other line - similar to the way a computer serial port works. This connection method is referred to as “single ended” instead of the “differential” method used by NMEA 0183 v2.0 devices.

The data format is largely the same between both systems, with v2.0 adding some extra sentence strings, and removing older (redundant) sentence strings from the specification. The situation is further complicated, as many manufacturers still use the old (“single ended”) method of connection because it is cheaper to implement.

So how can an older type NMEA device be connected to a newer type device?

Care is needed – it is possible to damage or overload the output of a newer differential device if it is incorrectly connected to an older device. This is because the older devices used ground as the return, whereas the newer devices actually drive the NMEA “**-B**” line between 5v and 0v. Thus, connecting this output to ground will result in high currents being drawn by the driver instrument, resulting in potential overheating and damage to the driver circuits.

To connect a new type differential device to an old type single-ended system, connect the NMEA “**+A**” output from the differential driver to the single-ended NMEA “**Rx**” or “**In**” input of the device. Leave the NMEA “**-B**” output floating. Connect the ground line of the differential output device to the ground of the single-ended device. This provides the required data signal return current path.

To connect an old type single-ended device to a new type differential device, connect the NMEA “**Tx**” or “**Out**” output from the single-ended driver to the differential NMEA “**+A**” input of the device. Connect the ground line of the single-ended output device to the NMEA “**-B**” input of the differential device. This provides the data signal return current path. If the NMEA “**-B**” input is left floating, then data corruption / errors may occur.

Please refer to the [Output Connections](#) section for example of these connection methods.

## Connections

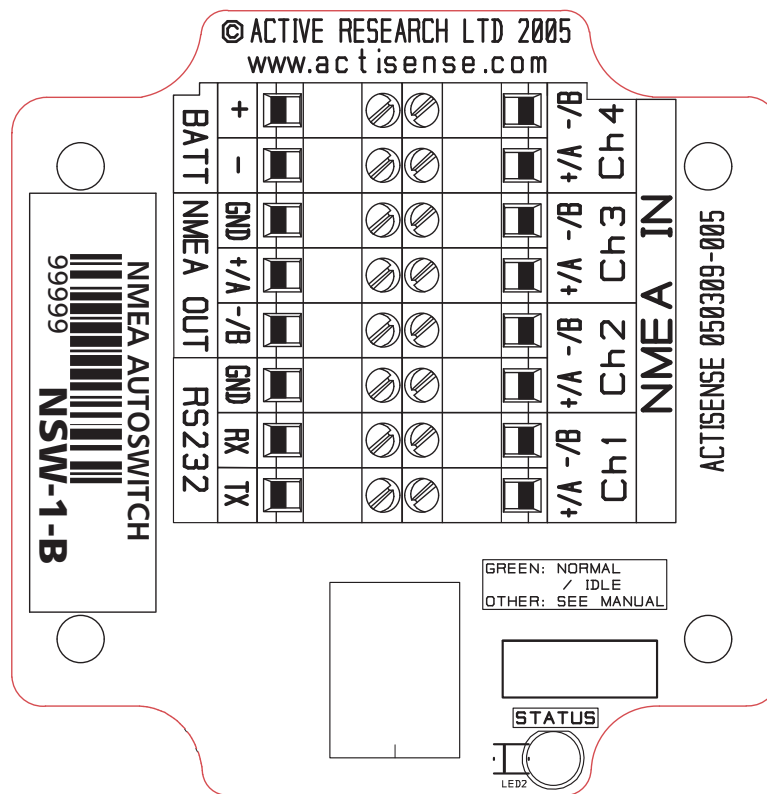

Figure 1 – All external connections

The NMEA Autoswitch (NSW-1) has screw-terminal “Phoenix” type external connections for: -

1. Four NMEA 0183 inputs.  
All NMEA 0183 inputs are of the differential opto-isolated type and use the unique **Actisense™** low current drain circuitry (2mA @ 2.0v) to conform in full with the NMEA 0183 marine electronic device network communication standard, and are flexible enough to interface to most fully and partially compliant devices.
2. An NMEA (data autoswitched) 0183 output.  
The NMEA 0183 output comprises of three connections: '+', '-' and 'Ground' and conforms in full to the NMEA 0183 standard. This allows the NDC to interface to various different devices that require any combination of these outputs.
3. An RS-232 input/output.  
The bi-directional RS-232 port is designed for direct connection to a Personal Computer (PC) or other marine device capable of interfacing to a standard RS-232 port.
4. Battery supply input.

**Note:**

1. To complete the NMEA 0183 standard all device interconnection NMEA cables used should meet the two-conductor, shielded, twisted pair configuration specification. The shield connection of these wires should be connected at the instrument end only to prevent ground loops.
2. Refer to the **Specifications** section for the full details on input/output specifications.
3. If the laptop / PC to be used with the NSW does not have an RS-232 serial port available, the **Actisense™ USB to RS-232 adapter cable** has been tried and tested to provide a compatible communications port. Please visit the **Actisense™ website** for full details on this, and other **Actisense™** products.

## Connecting to NMEA devices

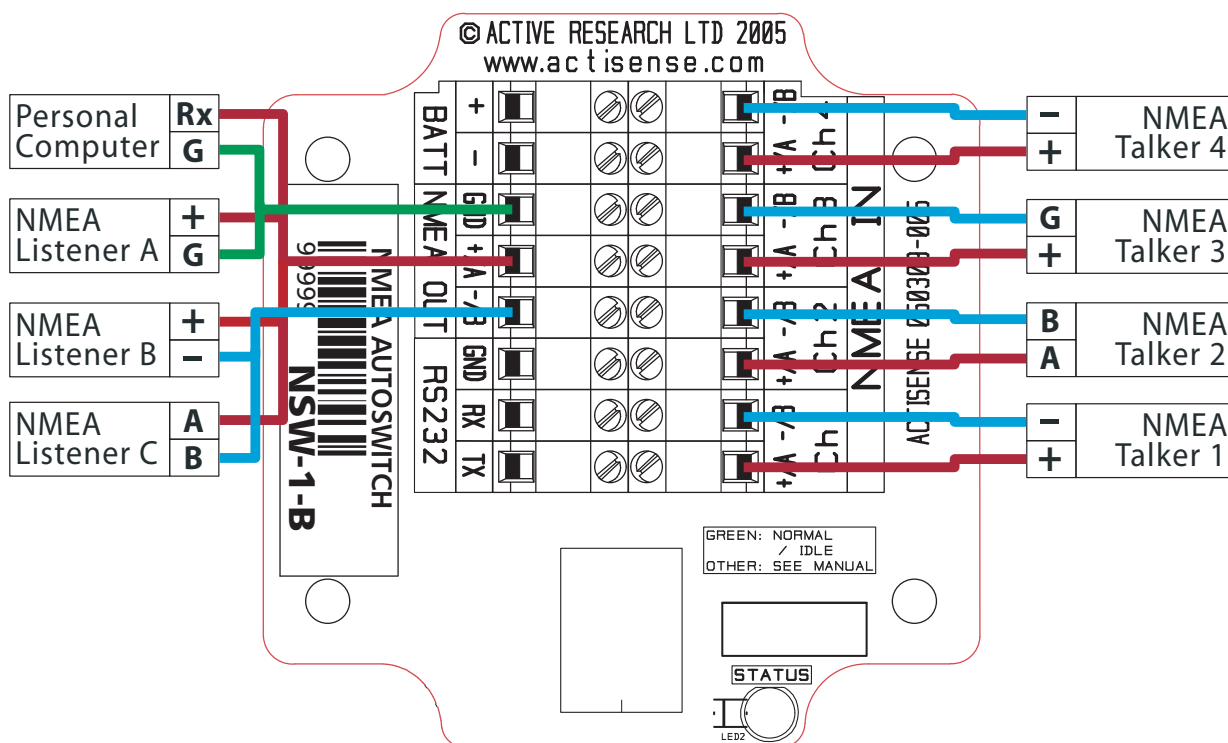

Figure 2 – NMEA 0183 connections

### NMEA 0183 Inputs

The NMEA 0183 differential opto-isolated inputs are designed to handle a variety of NMEA 0183 device output specifications. Please determine (from device manufacturer's information) if the device(s) required to be connected to the **Actisense™** NSW-1 conforms in full to the NMEA 0183 network communication standard. If it does not, the flexible **Actisense™** NSW-1 inputs should still be capable of interfacing with the device, though this is not guaranteed.

The diagram above shows a typical installation with both fully compliant NMEA devices with differential inputs/outputs, and non-differential output devices that output NMEA using the ground line as the "NMEA -" line.

**NMEA Talker devices 1, 2 and 4:** These devices conform in full to the NMEA 0183 standard. Devices 1 and 4 share the same connection ID's as the Actisense™ NSW, so connection is a simple matter of matching the ID's (refer to figure 2). Device 2 uses the RS485 convention connection ID's. Simply connect 'A' to '+/A' and 'B' to '-/B' (refer to figure 2).

**NMEA Talker device 3:** This device does not conform completely to the NMEA 0183 standard. However, by connecting '+' to '+/A' and its 'G/Ground' to the NSW "-/B" the NSW should be able to receive the NMEA data correctly.

### NMEA 0183 Output

The NMEA 0183 buffered output is capable of driving up to 20 NMEA 0183 fully compliant listening devices, or a mixture of NMEA 0183 devices and a Personal Computer (PC) communication port.

**NMEA Listener device's B and C:** These devices conform in full to the NMEA 0183 standard and their connection ID's match that of the NSW.

**Personal Computer:** Whilst the RS-232 port is designed for connection to a PC, the NMEA 0183 output is also capable of being read by most PC's. Simply connect '+' to 'Rx' and 'G' to 'Gnd' on a standard D-type (probably male) connector.

**NMEA Listener device A:** This device does not conform in full to the NMEA 0183 standard. However, by connecting '-' to '-/B' and 'G/Ground' to 'Gnd' the device should be able to receive the NMEA data correctly, though this is not guaranteed.

**Note:**

1. Wire colours are for guidance only.



## Other Connections

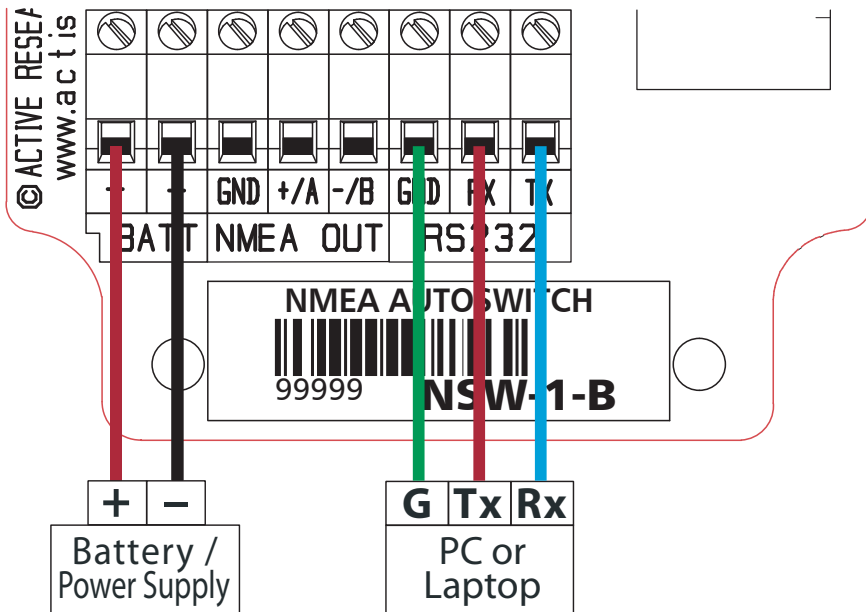

Figure 3 – RS-232 and Battery connections

### Connecting to a Personal Computer

The RS-232 port can be connected to a PC communications port using a cable conforming to the following specification:

1. A D-type female (socket) connector for the PC end of the cable.
2. A minimum of 3 cores are required in a shielded cable. Higher quality cable will naturally yield higher performance / higher Signal-to-Noise Ratio (SNR). Most typical cables have two twisted pairs inside. In this case, use one pair for the **TX** line and one for the **RX** line. Use the spare wire in each pair as ground, and connect the cable shield to ground only at the computer end.
3. The **TX** of the NSW-1 should be connected to the **RX** of the computer (standard D-type, pin 2) and the NSW-1 **RX** should be connected to the **TX** of the computer (pin 3). The **GND** of the NSW-1 should be connected to the PC's serial port ground (pin 5).

### Connecting to the battery supply

The **Actisense™** NSW-1 should be wired to the vessel's battery supply in the most direct manner possible, to minimize interference from other electronic devices. The cable used should be of sufficient gauge to handle the power requirements of the **Actisense™** NSW-1 (refer to the **Specifications** sections).

#### Note:

1. Wire colours are for guidance only.

## Troubleshooting guide

This guide will concentrate on all relevant troubleshooting issues above simple cable connection faults. Therefore, the cables between the NSW-1 hardware and any other devices should be checked as a matter of course, before continuing with this guide.

### Diagnostic LED

The NSW-1 hardware supports a tri-colour diagnostic LED that indicates the current operating mode of the hardware, or if an error has been detected during the self-test initiation process. Table 1 details what each LED colour represents and if any user interaction is required.

LED Colour / Flash Count	Mode / Error condition	Required user response
	Normal operation modes	The sequence below indicates a successful power-up of the NSW-1 and the commencement of data switching.
Red, No flashing	Start-up mode, No error	No response required. A normal operation mode that should last for no more than 1.5 seconds. Any longer indicates an error with the main program.
Red, No flashing	Flash updating mode, No error	No response required. LED will stay red for the duration of the flash update operation (using Flash Centre). Once operation complete, NSW hardware will be automatically reset.
Amber, No flashing	Initialise and self-test mode, No error	No response required. A normal operation mode that follows after the Start-up mode and should last for approximately 1 second.
Green, No flashing	Normal and no data mode, No error	No response required. A normal operation mode that follows the Initialise and self-test mode. Indicates that no error was detected during the self-test operation.  Also indicates that no data is currently being received by the NSW-1 hardware.
Green, Flashing (1-10 per second)	Normal and data Rx mode, No error	No response required. A normal operation mode that indicates that data is currently being received (on at least one channel) by the NSW-1 hardware. Flash rate proportional to Rx rate.
	Error conditions	If the error persists the NSW-1 unit should be returned to <b>Actisense™</b> (refer to the <b>Contact Information</b> section).
Amber, Flashing (Once every 4 seconds)	Error trap mode, EEPROM memory error	An error with the EEPROM memory has been detected during the self-test mode.  Reset the NSW-1 hardware.

**Table 1 – Diagnostic LED colours**

## Specifications

Parameter	Conditions	Min.	Max.	Unit
<b>Supply</b>				
Supply voltage		8	35	V
Supply current (see note 1)	Supply voltage = 12v	26	30	mA
	Supply voltage = 24v	16	18	mA
<b>NMEA</b>				
Input voltage between +/-	Logical '1'/stop bit	-15.0	0.5	V
	Logical '0'/start bit	4.0	15.0	V
Input current	Maximum is under +35v overload condition	2.0	30	mA
Differential input voltage	Required level for NMEA to be detected	1.8	2.0	V
Output voltage between +/- and ground (see note 2)	Logical '1'/stop bit	0.0	0.5	V
		4.8	5.2	V
Output current (see note 2)	At maximum load, drive voltage reduces to 2v	-	32	mA
Output short circuit current.		50	55	mA
Baud rate - fixed (see note 3)			4.8	kbit/sec
Data propagation delay		1.0	100	ms
<b>RS-232</b>				
Input voltage range		-15	+15	V
Input voltage threshold	LOW	0.8	1.2	V
	HIGH	1.7	2.8	V
Output voltage swing	Loaded with 3kΩ to Ground	±5	±9	V
Output resistance	(RS232 Vout = ±2v)	300		Ohms
Output short circuit current (Infinite duration)			±18	mA
Baud rate (see note 4)			38.4	kbit/sec
Data propagation delay		1.0	100	ms
<b>General</b>				
Ambient temperature		-20	+70	°C

**Table 2 – NSW-1 specifications**

All specifications are taken with reference to an ambient temperature ( $T_A$ ) of +25°C.

**Note:**

1. Current consumption measured under no-load conditions
2. NMEA output is RS-485 compatible.
3. NMEA 0183 inputs and outputs on the NSW-1 are fixed to 4800 baud
4. RS232 baud rate is fixed at 38400 baud on the NSW-1

## Company Information

Active Research Limited  
5, Wessex Trade Centre  
Ringwood Road  
Poole  
Dorset  
UK  
BH12 3PF

Telephone: 01202 746682 (International : +44 1202 746682)  
Fax: 01202 746683 (International : +44 1202 746683)

**Actisense™** on the Web: For advice, support and product details

E-mail: [support@actisense.com](mailto:support@actisense.com)  
Website: [www.actisense.com](http://www.actisense.com)

**Active Research** on the Web: For specialist consultancy and customisation

E-mail: [support@activer.com](mailto:support@activer.com)  
Website: [www.activer.com](http://www.activer.com)

