

Professional Type Approved NMEA[®] 0183 Multiplexer Install/User Manual

Important Notices

The device to which this manual relates complies with the Electromagnetic Compatibility requirements according to IEC 60945:2002-08, DNVGL-CG-0339:2019 & IACS UR E10 Rev7. The unit should always be used in conjunction with appropriately approved, shielded cable and connectors as per NMEA 0400 to ensure compliance. A declaration of conformity is available for download at www.actisense.com.

If the device to which this manual relates is to be installed within five metres of a compass, please refer to the 'Compass Safe Distance' section in the 'Technical Specifications' table.

Trademarks and Registered Trademarks

Actisense® and the Actisense logo are registered trademarks of Active Research Limited (Ltd). All other trademarks are the property of their respective owners.

The NMEA® name and NMEA logo are copyright held by the NMEA. All uses in this manual are by permission and no claim on the right to the NMEA name or logo are made in this manual.

Fair Use Statement

The contents of this manual may not be transferred or copied without the express written permission of Active Research Ltd. Copyright © 2021 Active Research Ltd. All rights reserved.

Technical Accuracy

To the best of our knowledge the information contained in this document was correct at the time it was produced. Active Research Ltd cannot accept liability for any inaccuracies or omissions.

The products described in this manual and the specifications thereof may be changed without prior notice. Active Research Ltd cannot accept any liability for differences between the product and this document. To check for updated information and specifications please check www.actisense.com.

Active Research Ltd will not be liable for infringement of copyright, industrial property rights, or other rights of a third party caused by the use of information or drawings described in this manual.

Product Registration

Please register your product via the online form at <https://actisense.com/product-registration>

Your product package includes a unit serial number. The serial number is six digits long and can be found below the barcode on the label. Your registration will assist Actisense Support to link

your product to your details, simplifying any future assistance you may require.

Product Guarantee

All Actisense products are provided with a 5 year guarantee upon product registration. To register your product, visit <https://actisense.com/product-registration>

If you suspect that the unit is faulty please refer to the Troubleshooting Section of the User Manual before contacting support.

It is a requirement of the guarantee that all installations of electronic equipment follow the NMEA 0400 specification. Any connection to a battery or power supply must meet the mandatory essential safety requirements that may be imposed by local regulatory agencies.

Actisense products are intended for use in a marine environment, primarily for below deck use. If a product is to be used in a more severe environment, such use may be considered misuse under the Active Research Ltd guarantee.

Product Disposal

Please dispose of this product in accordance with the WEEE Directive. The product should be taken to a registered establishment for the disposal of electronic equipment.

Contents Page

• Important Notices	2
• Trademarks and Registered Trademarks	2
• Fair Use Statement	2
• Introduction	4
• Installation Warnings	4
• Software Updates	4
• Features	5
• NMEA wire colour coding	5
• PRO-MUX-2 Connections	6
• Operating Modes	11
• Hard-wiring the operating modes	11
• Web Browser Configuration	12
• Troubleshooting Guide	15
• IEC 61162 Interface Compliance Information	16
• Technical Specification	20
• Technical Support and the returns procedure	22

Introduction

The PRO-MUX-2 is designed to suit the majority of NMEA 0183 systems and is ready to go 'out of the box' by simply hard-wiring the two mode inputs as required. The manually configurable basic modes of operation include buffer modes, autoswitch modes, and combine modes. For all other configurations, leaving the mode inputs floating selects the 'web based' user configuration mode.

The configuration tool allows full customisation of the PRO-MUX-2, and as the configuration tool is web based it is compatible across all popular Operating Systems. The PRO-MUX-2 supports a direct Ethernet connection to a PC without the need for a specialised Ethernet crossover cable.

Installation Warnings

All warnings and notices must be followed to ensure the correct operation of the PRO-MUX-2. Incorrect installation may invalidate the guarantee.

It is highly recommended that all of the installation instructions are read before commencing the installation.

There are important warnings and notes throughout the manual that should be considered before the installation is attempted.

Warning 1: Accuracy.

The Actisense PRO-MUX-2 is designed to accurately transfer data from input to output. When the PRO-MUX-2 is in a Basic Mode no data integrity checking is performed, therefore any incomplete, inaccurate or corrupt data received on a PRO-MUX-2 input will be duplicated to the PRO-MUX-2 outputs. In contrast, PRO-MUX-2 Smart Modes do use the sentence checksum (if available) to remove incomplete and corrupted data, however, the accuracy of the data fields in a valid sentence still remains the responsibility of the NMEA Talker that generated the data.

Warning 2: Installation and Operation.

This product must be installed and operated in accordance with the instructions provided. Failure to do so could result in personal injury, damage to your boat and/or poor product performance.

Warning 3: Installation Code of Practice.

When wiring the power supply to the PRO-MUX-2 ensure the isolation switch is off. Wiring the PRO-MUX-2 while the connection is live may damage the PRO-MUX-2 and is in breach of the guarantee. Any connection to a battery or power supply must meet the mandatory essential safety requirements that may be imposed by local regulatory agencies. All wiring should be in accordance with the requirements of the NMEA 0400 installation specification.

Warning 4: Mounting Requirements.

Select a flat location to mount the PRO-MUX-2. Mounting on a contoured surface may cause damage to the case.

Do not mount the PRO-MUX-2 while the device is powered, or the cable harness is connected.

Note that the connectors are unplugged easily when mounting or removing the PRO-MUX-2.

Software Updates

The PRO-MUX-2 units have built-in firmware which is held in flash memory, allowing quick and easy upgrades using the latest Actisense Toolkit. It is highly recommended that the firmware is kept up to date in the PRO-MUX-2.

The currently installed PRO-MUX-2 firmware version can be viewed on the PRO-MUX-2 Configuration Tool 'Home' page in the 'Main Application' section. Details of the latest PRO-MUX-2 firmware version release can be found on the Actisense website's PRO-MUX-2 'Downloads' page.

Intelligent Type Approved NMEA Multiplexer - PRO-MUX-2

Features

- Type-Approved (RINA).
- 8x Configurable Opto-isolated inputs.
- 6x Configurable ISO-Drive™ isolated outputs.
- 1x Bi-directional, configurable, isolated serial port.
- Automatic baud rate matching on inputs.
- Advanced data filtering / routing.
- Free firmware updates making the device “future-proof”.
- 1 x Alarm output relay (N/O and N/C contacts).
- Mode input-pins to set operating mode without the need for a PC.
- Diagnostic LED’s on all inputs and outputs.
- Alarm status LED / Mode LED / Bi-color status LED.
- Panel mountable.
- Using the configuration tool, each NMEA 0183 output can be configured to communicate at independent baud rates.
- Data statistics and load indication via web tool.
- Designed for 12 and 24 Volt supply.
- Pluggable connector system supports both screw and screwless terminals.
- Double Galvanic isolation between all inputs and outputs. Galvanic isolation to battery supply.

NMEA wire colour coding

The wire colours used in this manual are in accordance with the NMEA 0183 specification (v.4.10, June 2014) and are for illustration purposes only. Please ensure you check the wiring colours given in the installation instructions for any devices you wish to interface to the PRO-MUX-2. Not all manufacturers follow this standard colour coding which can lead to confusion.

Currently, the specified NMEA0183 signal colour coding for individual wires is as follows:

- Talker A - White 
- Talker B - Brown 
- Listener A - Yellow 
- Listener B - Green 

PRO-MUX-2 Overview

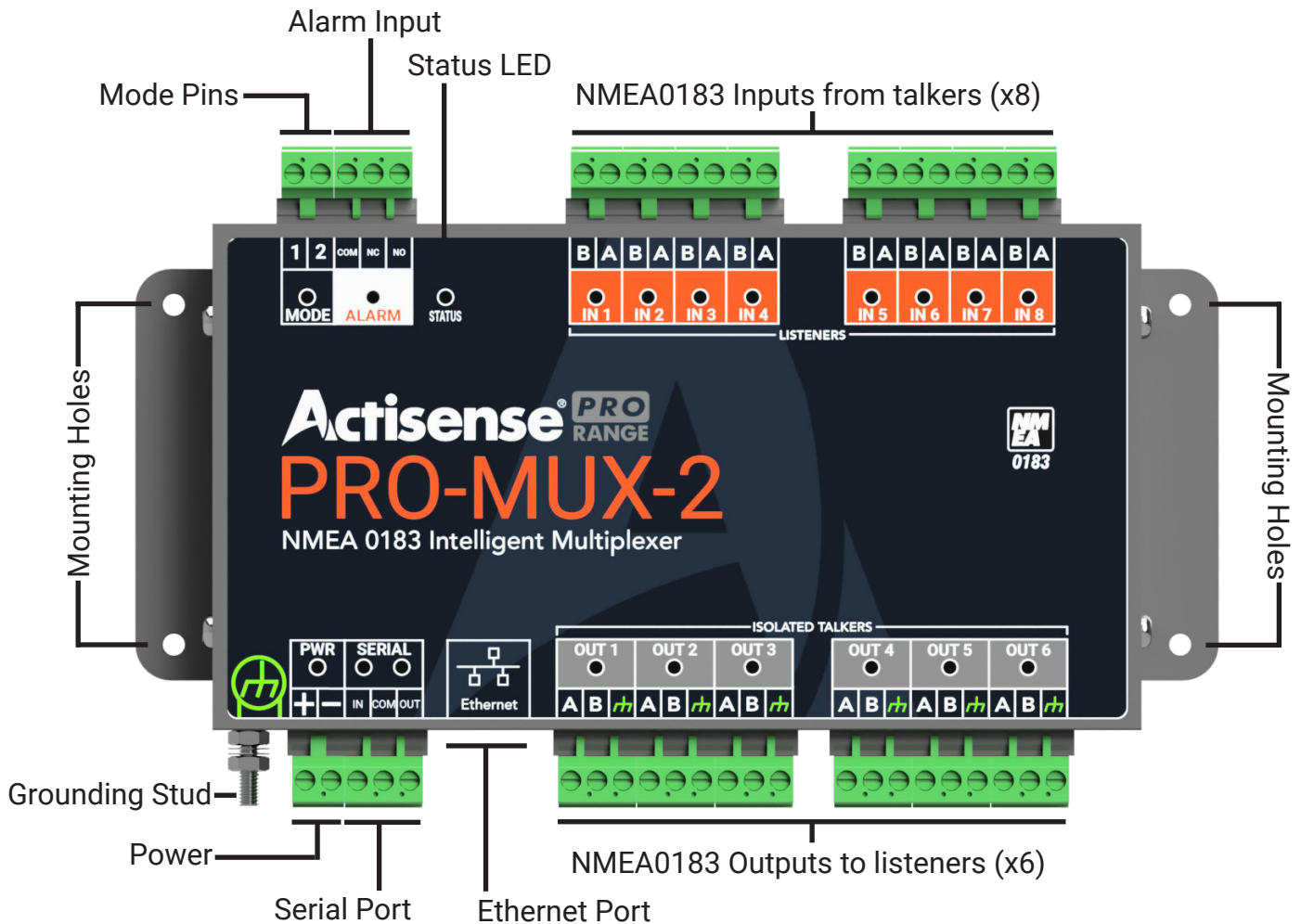

PRO-MUX-2 Connections

Terminals

The PRO-MUX comes supplied with high quality 2-way and 3-way rising clamp connectors which are tightened with screws.

Screwless spring-loaded connectors are also available as a optional extra and are available via your distributor.

Power Supply Connections

- The PRO-MUX-2 requires a power source providing between 10 to 35 Volts DC.
- The PRO-MUX-2 "+" terminal should be connected to the vessel power supply "+" terminal via the correctly rated fuse (in accordance with the NMEA 0400 installation standard).
- The PRO-MUX-2 "-" terminal should be connected to the vessels DC ground plate.
- The input supply connection has continuous reverse polarity and ESD protection.
- Red and Black wires are shown here as they are the most common designation for power and ground.

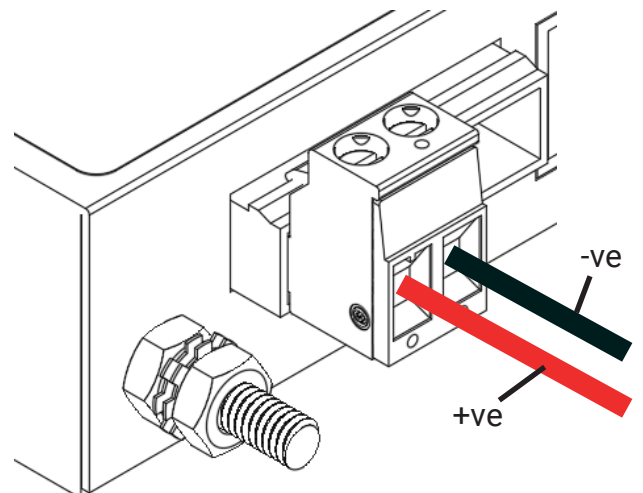

Intelligent Type Approved NMEA Multiplexer - PRO-MUX-2

Standard Serial Port Connections

- The PRO-MUX-2 serial port connector allows a serial device/adaptor to be connected easily.
- The Standard RS-232 wiring designation is as shown below.
- Connect the **Tx** (pin 3) terminal **from** your serial device to the PRO-MUX-2 "IN" terminal
- Connect the **Rx** (pin 2) terminal **from** your serial device to the PRO-MUX-2 "OUT" terminal
- Connect the **GND** (pin 5) terminal **from** your serial device to the PRO-MUX-2 "COM" terminal

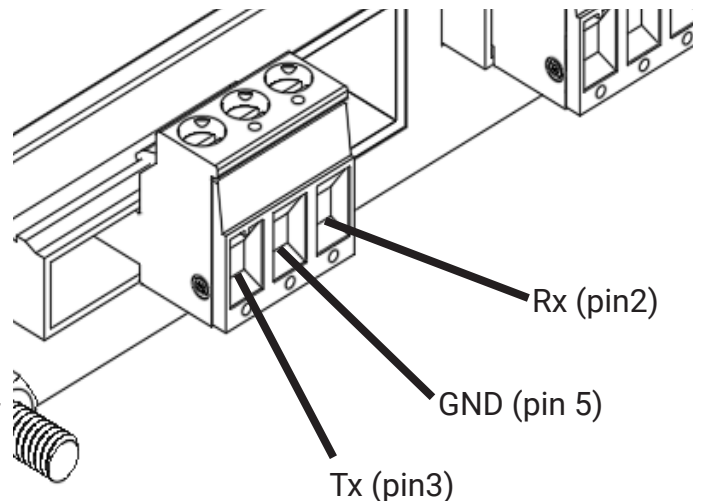

N.B Wire colours may vary between 3rd party cables/adapters
(Pin numbers refer to a standard DB9 connector)

USB - Serial Port Connections

- Should you require to connect your PRO-MUX-2 to a PC via a USB connection, Actisense have provided a way to achieve this using our **USBKIT-PRO (Universal Serial adaptor)** which contains a USB-SERIAL converter with the necessary Rx/Tx and GND connections.

Ethernet Connection

- An Ethernet port is provided as a means of correctly configuring your PRO-MUX-2.
- Use either a standard Ethernet patch cable with an RJ45 plug to connect directly to a PC.
- Alternatively, the PRO-MUX-2 can be connected to an Ethernet switch.
- Insert the RJ45 plug into the PRO-MUX-2 "Ethernet" terminal until a click is heard. To remove the RJ45 plug, push down on the locking clip and gently pull the cable away from the "Ethernet" terminal.

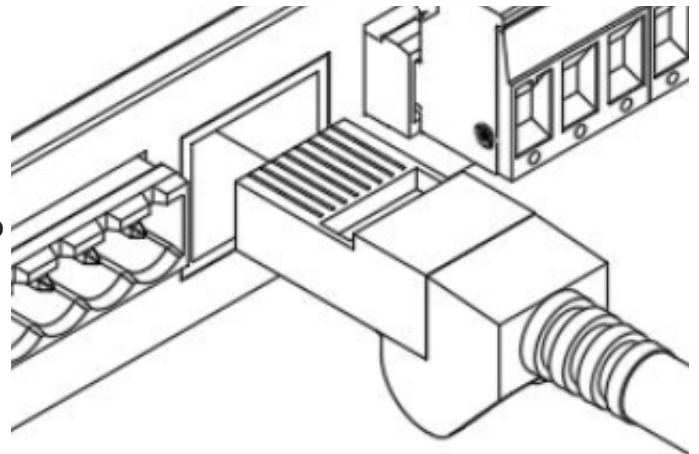

Ground Connection

- The PRO-MUX-2 must be properly grounded using the grounding stud provided.
- This connection should be made using a robust crimped connection and routed back to the vessels 'boat' ground.

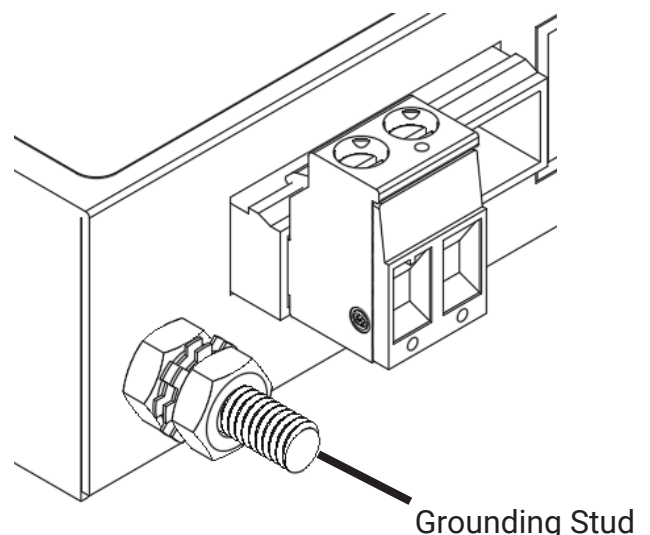

Alarm Connections

- The PRO-MUX-2 alarm functionality provides the vessel operator with two notification methods when potential safety issues are detected during a voyage, allowing remedial action to be performed. Each alarm can be configured to generate and send an NMEA 0183 ALR sentence containing the relevant alarm details to the chosen output, plus the option of triggering the PRO-MUX-2's Alarm Relay output that could be connected to a variety of visual or audible alert devices. Examples of the three alarm conditions that can be detected are detailed below.

Autoswitch ALARM:

- Multiplexers are often used to add redundancy to a system. GNSS receivers, for example, are often duplicated for safety reasons, however combining data from two devices of the same type is not recommended as the Listener will become confused. This is where the concept of the Autoswitch helps as it will only pass through data from one source/input, starting with the primary data source/input and automatically switching over to the secondary (backup) source/input if the primary data source is deemed no longer valid (e.g. due to equipment failure, cable failure, or in the case of a GPS/VHF, antenna failure). This alarm will trigger when the Autoswitch has switched to the secondary/backup data source, indicating that the system's redundancy has been lost and the issue affecting the primary data source should be investigated.
- **0183 output example:**
- **\$MXALR,000655,002,PRO|<serial number of device>|Autoswitch:IN1>IN2**

Data Overload ALARM:

- When routing and combining data from multiple inputs into an output, the chance that the volume of buffered data is higher than the bandwidth available to an output is high. In this scenario, the PRO-MUX-2 will intelligently drop whole sentences, avoiding the issue of data corruption that could confuse a Listening device, however random sentence data loss will occur. This will trigger the Data Overload alarm, indicating that the routing configuration should be modified to intelligently filter the data volume below what the output can cope with.
- **0183 output example:**
- **\$MXALR,000655,001,PRO|<serial number of device>|Combine:Data overload**

Low Voltage ALARM:

- The PRO-MUX-2 continuously monitors its own battery voltage supply. Should that supply drop below a pre-set level, the Low Voltage alarm will be triggered, indicating that there is an issue with the battery supply to the PRO-MUX-2, potentially giving forewarning of a total battery supply failure.
- **0183 output example:**
- **\$MXALR,000655,001,PRO|<serial number of device>|Voltage Alert:PWR:10.2V**
- Note: the "<serial number of device>" value in the examples above will be replaced with the unique serial number of the PRO-MUX-2 device that sent the alarm sentence, allowing the operator to uniquely identify the unit.

Monitoring Alarm Connections

- The triggering of these alarms may be monitored in several ways, depending upon the user's requirements.
- NMEA 0183 Alarm (ALR) sentences will typically be sent to a Multi Function Display (MFD) capable of displaying the contents of the ALR sentence, allowing the user to interpret the source and act accordingly. These alarm message could also be sent to a Voyage Data Recorder device (if available) or a Wi-Fi Gateway allowing remote monitoring.
- The Alarm Relay contacts can be connected to a wide range of audible and/or visual alarm devices in order to notify the operator that an alarm event has occurred. On larger vessels, with a bridge monitoring system, the Alarm Relay contacts can be wired into the overall monitoring system for the vessel, allowing these alarm conditions to viewed in a central place along with any other alarms. Please consult the instruction manual of any monitoring system to see how this would be achieved.
- The Alarm contacts have a common connection (COM) and an 'NO' (normally open) and NC (normally closed) connector to suit your requirements for alarm installation. See page 6 for alarm contact connector position.

NMEA 0183 Talker and Listener Designations

- The NMEA have updated the NMEA 0183 specifications to ensure a consistent naming convention is used for labelling ports. The designation follows the same rules as used for Tx and Rx labelling but uses the terminology “Talker” and “Listener” instead.
- A “talker” is the device transmitting data. A “listener” is the device receiving that data.
- The **Input / Receiving / (Rx) port** is labelled as a **LISTENER** on the PRO-MUX-2.
- The **Output / Transmitting / (Tx) port** is labelled as a **TALKER** on the PRO-MUX-2.

PRO-MUX-2 “Listener” Connections

The PRO-MUX-2 has 8 input connections, labelled IN-1 to IN-8.

- Inputs are labelled ‘A’ and ‘B’ in line with the NMEA specification for labelling NMEA0183 signal pairs.
- If your “TALKER” follows the NMEA wire colour convention, the wires should be coloured as follows:

TALKER ‘A’/+	: WHITE	
TALKER ‘B’/-	: BROWN	
- If your wire colours do not follow the NMEA convention, you will need to consult your device manual and find which wire colours correspond to ‘A’/+ and ‘B’/- and attach accordingly.
- If your “talker” device has only ‘A’ and ‘GND’ output wires, connect the ‘GND’ wire to ‘B’/-

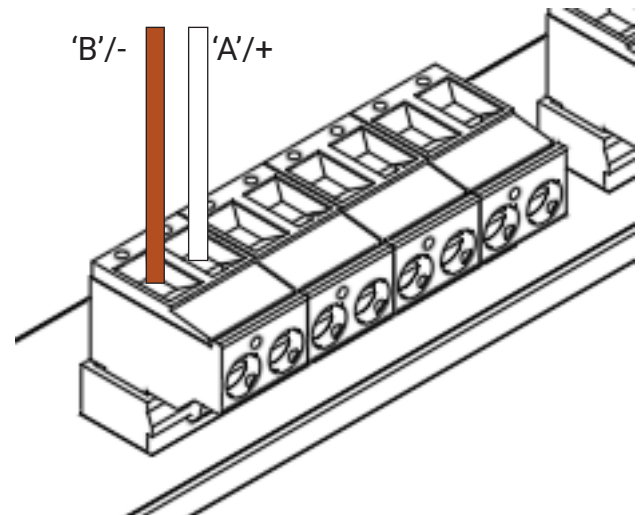

PRO-MUX-2 “Talker” Connections

The PRO-MUX-2 has 6 output connections, labelled OUT-1 to OUT-6.

- Outputs are labelled ‘A’ and ‘B’ in line with the NMEA specification for labelling NMEA0183 signal pairs.
- If your “LISTENER” follows the NMEA wire colour convention, the wires should be coloured as follows:

LISTENER ‘A’/+	: YELLOW	
LISTENER ‘B’/-	: GREEN	
- If your wire colours do not follow the NMEA convention, you will need to consult your device manual and find which wire colours correspond to ‘A’/+ and ‘B’/- and attach accordingly.
- The shield from each listener should be connected to the ‘GND’ connector on the output terminal.
- The RF ground stud should be connected to the vessels RF ground plate using a minimum conductor size of 8 AWG in accordance with the NMEA 0400 installation standard. Use a crimped connector to securely bond the RF wire.

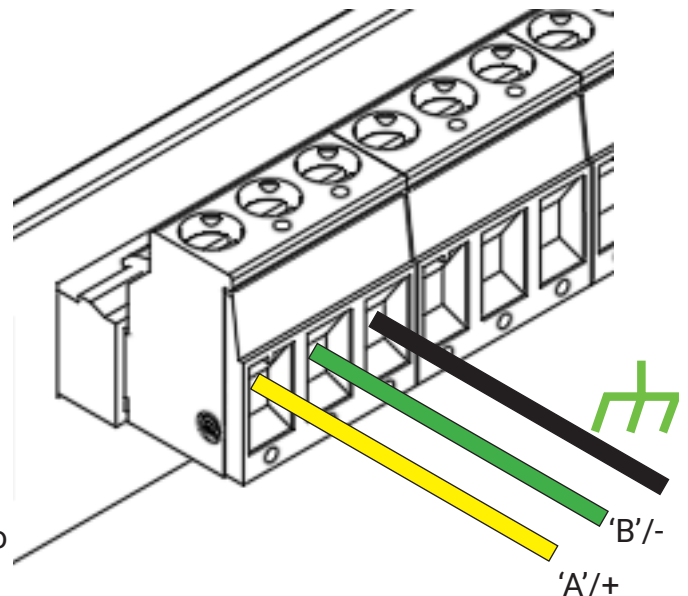

Intelligent Type Approved NMEA Multiplexer - PRO-MUX-2



Operating Modes

The PRO-MUX-2 can be configured manually using the 'Mode' pins (also referred to as 'hard-wiring') or user configured via the Configuration Tool. Manually configuring the PRO-MUX-2 takes priority over any user configuration. An internet connection is not required to access the configuration tool.

Hard-wiring the operating modes

Connect the mode pins on the device to the power input pins as indicated in the table below. A wire of 22-24 AWG will be sufficient for this purpose.

+	= Connect to '+' on Power Input
-	= Connect to '-' on Power Input
N/C	= No connection

Mode Name	Description	Mode Pin 1	Mode Pin 2	LED Flashes
Combine 1	Inputs 1-8 Output baud rates follow Input 1 	-	N/C	1
Combine 2	Inputs 1-8 Output baud rates follow Input 2 	+	N/C	2
Autoswitch	Smart Autoswitch Input 1 or 2 Output baud rates follow Input 1 baud rate 2000ms Switch delay 	N/C	-	3
User Defined - 'User 1'	PC/Remote Custom Configuration	-	-	4
User Defined - 'User 2'	PC/Remote Custom Configuration	N/C	+	5
User Defined - 'User 3'	PC/Remote Custom Configuration	+	+	6
User Defined - 'User 4'	PC/Remote Custom Configuration	-	+	7
User Defined - 'User 5'	PC/Remote Custom Configuration	+	-	8

Web Browser Configuration

- The web-based configuration tool for the PRO-MUX-2 is built in, and can be accessed using the ethernet configuration port (see page 7).
- As it is web-based, the configuration tool is compatible with all popular web browsers and operating systems.
- NOTE: An internet connection is not required to access the configuration tool.

Standard Ethernet Networks

- If the PRO-MUX-2 is connected to an ethernet network containing both DHCP and DNS servers, launch any of the popular web browsers.
- Replacing 'xxxxxx' with the serial number of your PRO-MUX-2, type the following command into the address bar.

http://promux-xxxxxx

- The following web-page will now be displayed allowing configuration of the PRO-MUX-2
- Please see PRO-MUX-2 Configuration manual for full details regarding set-up.

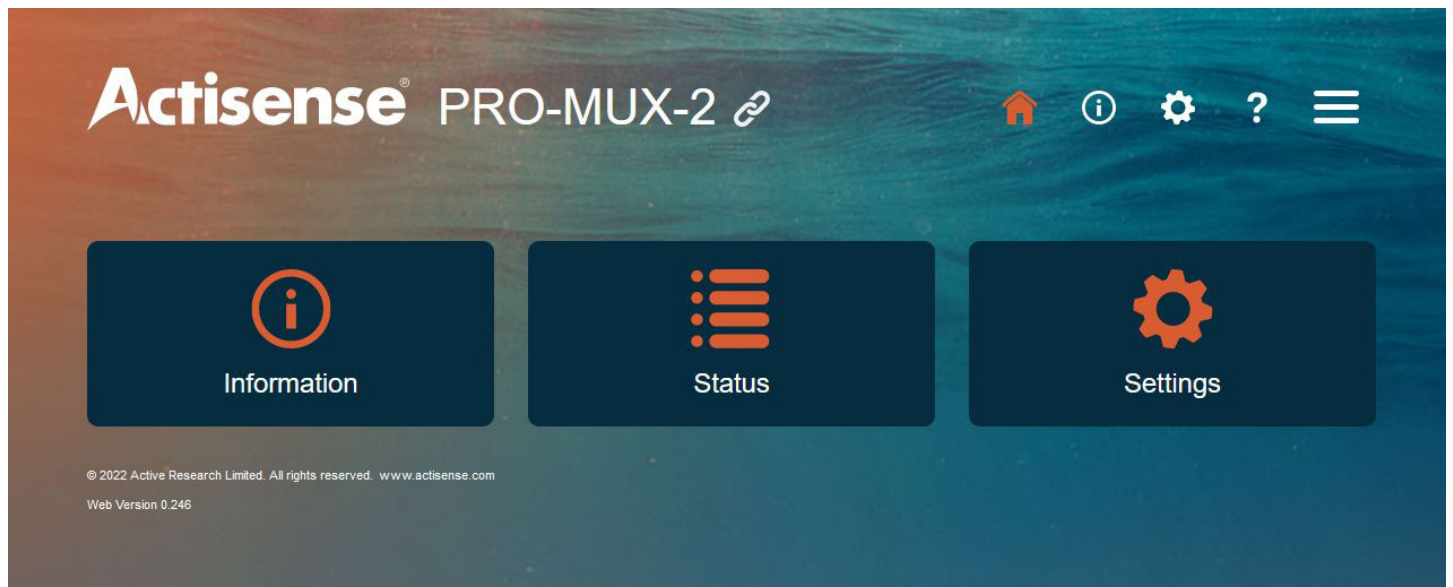

Direct connection or basic ethernet networks

- If the PRO-MUX-2 is connected directly to a PC, or the ethernet network does not have a DHCP server, the PRO-MUX-2 will communicate using the auto-IP by default.
- A standard Ethernet cable can be used for the connection to your PC. The PRO-MUX-2 will automatically detect this. You do not require a cross-over cable.
- The auto-IP process can take up to 60 seconds to complete.
- The PC's 'Local Area Connection' must also be set-up to use auto-IP in order to communicate on this network. Most PC's are set-up to do this by default. If needed, instructions on how to do this using Windows 10 are detailed overleaf (other Windows operating systems will be similar).

NOTE: Administrator privileges are required to carry out these modifications.

- Once the PC and PRO-MUX-2 are using the same IP address range, launch any popular web browser.
- Replacing 'xxxxxx' below with the serial number of your PRO-MUX-2, type the following command into the address bar.

http://promux-xxxxxx

- The web-page shown above will now be displayed allowing configuration of the PRO-MUX-2.

Intelligent Type Approved NMEA Multiplexer - PRO-MUX-2

Configuring 'Local Area Connection'

- Search for 'Network Status' on your PC and open the 'Network Status' menu

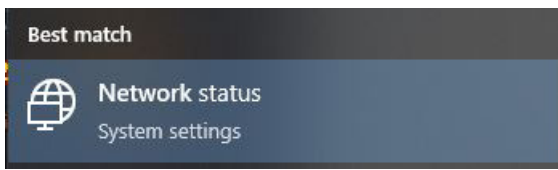

- In the 'Network Status' menu, under 'Advanced Network Settings', select 'Change Adapter Options'

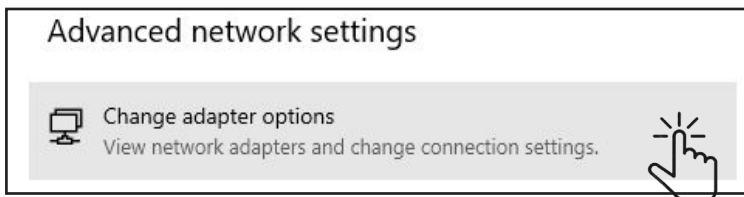

- 'Right-click' on your 'Local Connection' and select 'Properties'

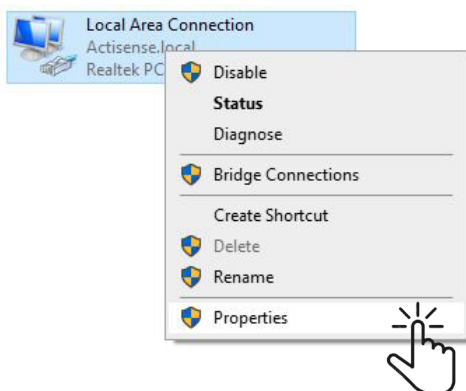

- Select 'Internet Protocol Version 4(TCP/IPv4)' and leave the box on the RHS checked.
- Click on 'Properties'

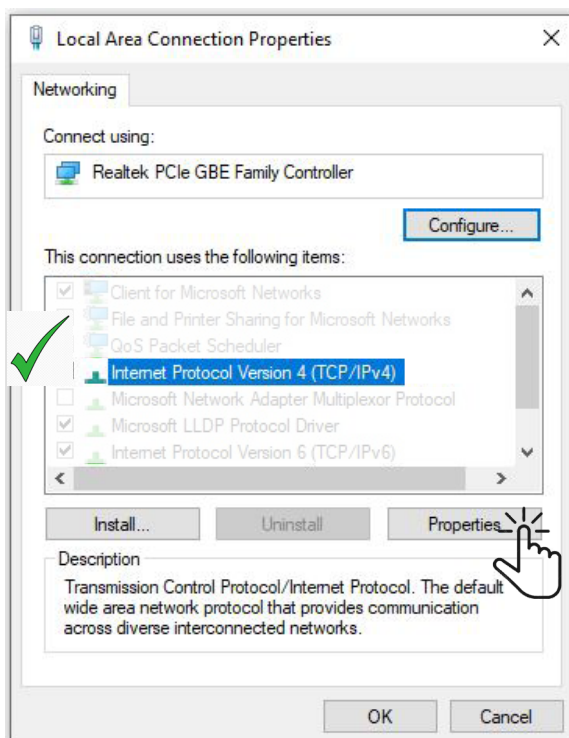

Configuring 'Local Area Connection' (cont'd)

- Under the 'General' tab in 'Properties' make sure that:
 - **'Obtain an IP address automatically'** is selected.
 - **'Obtain DNS server address automatically'** is selected.
- Under the 'Alternate Configuration' tab make sure that:
 - **'Automatic private IP address'** is selected
- Click **'OK'** to accept these changes, and close the 'local connections window'

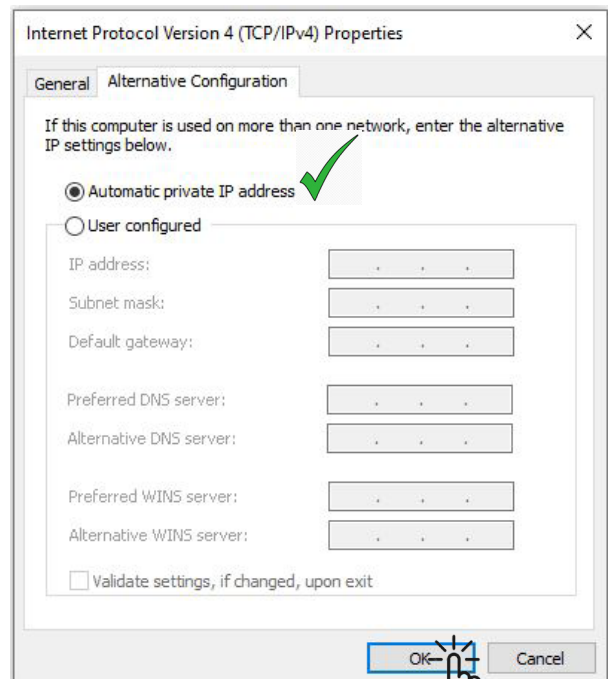
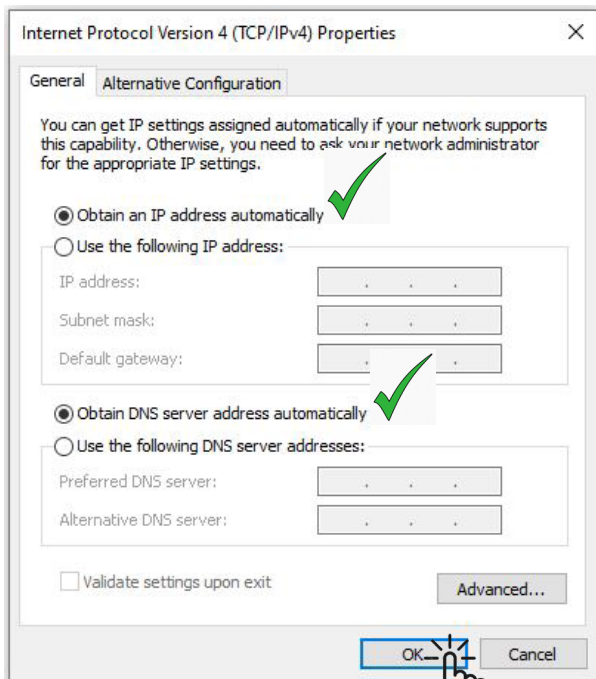

Intelligent Type Approved NMEA Multiplexer - PRO-MUX-2

Troubleshooting Guide

First level PRO-MUX-2 diagnostics / fault finding can be performed by observing the LED behaviour. The normal behaviour of the PRO-MUX-2 LEDs is described on the next page. If the LEDs are not behaving as expected, this will indicate a fault in either the device connected to the PRO-MUX-2, the wiring/connections, or the PRO-MUX-2 itself.

Some common checks to perform on all terminals of the PRO-MUX-2 if the correct LED behaviour is not displayed:

- Connectors are fully inserted
- All pins of the connector are in the correct location (not overlapping into another port position)
- Wires are terminated firmly and correctly (check polarity)

LED	Colour	State	Description	User action
PWR	Blue	Pulsing	Indicates presence of power	None required
IN (INCLUDING 'SERIAL IN')	Green	Flashing	Data available on input indicated by LED.	No action required
	-	Off	No data available on this input or autobaud detection in progress (up to 20 seconds)	Check if connected Talker is sending data. If it is, review configuration.
OUT (INCLUDING 'SERIAL OUT')	Orange	Flashing/ solid	Flashes at a rate determined by baud rate and data length. If available bandwidth is nearly full, LED may appear solid instead of flashing	None required
STATUS	Red	Flashing / solid	Buffer Full – Overload condition, sentences are being dropped.	Use a web browser to review configuration and correct overload condition.
	Yellow	Flashing / solid	Warning, buffer is filling. Duplicate deletion is managing to maintain output capacity by deleting older copies of sentences	Review configuration to understand the required rates of sentences which is acceptable to any connected device
	Green	Flashing / solid	Normal operation. No data issues.	No action required
	-	Off	No data passing through outputs. Either no input data, or if IN LED is active it means all data is blocked.	Check if the connected Talker is sending data. If it is, review configuration.
Ethernet	Green	Flashing	Data activity on the Ethernet port	No action required
	Yellow	On	Indicates line speed at 100Mbps	No action required
		Off	Indicates line speed at 10Mbps	
-	Off	No data available	Check that the Ethernet network is operational.	
ALARM	Red	On	Indicates alarm conditions have been met.	Review status page in browser to understand alarm source.
MODE	Green	Pulsing / Flashing	Pulsing - User defined mode selected, Flashing - Pre-defined operating mode selected according to mode pins. Number of flashes = operating mode number	No action required
PWR and STATUS (Combined)	Power = blue Status = red	Power = on (solid) Status = on (solid)	Critical HW Error Both Power & Status LEDs are solid	Return to manufacturer if this persists after a power reset

IEC 61162 Interface Compliance Information

This section provides the required documentation per IEC 61162 Section 4 for the Actisense PRO-MUX-2 Professional Range Intelligent NMEA 0183 Data Combiner.

The PRO-MUX-2 is designed and Type Approved for IEC 61162 compliance (see section 4.1h for specific standard versions and dates).

4.1a - Identification of A and B Signal Lines

The PRO-MUX-2 uses differential signaling compliant with IEC 61162 and EIA-422/ITU-T V.11 standards.

Signal Line Identification

- **Line A (Data+)**: Non-inverting differential signal line (positive)
- **Line B (Data-)**: Inverting differential signal line (negative)
- **Shield/Ground**: Optional cable shield for EMI protection

Listener Inputs 1-8

- Pin 1: Signal Line "A" (Data+)
- Pin 2: Signal Line "B" (Data-)

Talker Outputs 1-6

- Pin 1: Signal Line "A" (Data+)
- Pin 2: Signal Line "B" (Data-)
- Pin 3: Shield/Ground connection

Note: Correct polarity is essential. Connect talker 'A' to listener 'A', and talker 'B' to listener 'B' to enable communication. Cable shields should only be connected at the talker (output) end to prevent ground loops.

Bi-directional Serial Port

The Serial Port uses identical electrical circuitry to the inputs and outputs described above, but follows RS-232-style terminal labeling:

- Pin 1: Signal Line "In" (electrical equivalent to Input Signal Line "A")
- Pin 2: Signal Line "Out" (electrical equivalent to Output Signal Line "A")
- Pin 3: Signal Line "Common" (electrical equivalent to both Input & Output Signal Line "B")

Note: If it's preferable to connect the Serial Port cable shield at the PRO-MUX-2 end, connect the shield to the PRO-MUX-2 Grounding Stud.

4.1b - Output Drive Capability as a Talker

The PRO-MUX-2 talker outputs comply with IEC 61162 requirements for driving multiple listener loads.

Talker Output Specifications

- **Output voltage (differential)**: 2.0V minimum (fully loaded), up to 5.0V (unloaded)
- **Output current capability**: 20mA maximum per output
- **Load driving capability**:
 - Exceeds IEC 61162-1 requirement (of a minimum 3 listener loads)
 - Theoretical maximum: Up to 10 compliant listeners (2mA each)
 - **Recommended practice**: 1 talker to 1 listener for optimal reliability, to manage risk of non-isolated equipment
- **Fully isolated/floating output**: Full galvanic isolation helps break ground loops and ground potential difference.

4.1c - List of Approved Sentences, Unused Fields, Proprietary Sentences and Transmission Intervals

Approved NMEA 0183 / IEC 61162 Sentences transmitted

Internally generated Sentences

- **\$MXTXT** - Standard text message sentence (transmitted on device restart/power-up)
- **\$MXALR** - Standard alarm sentence (transmitted when configurable alarm events are triggered: once only, or repeats every 1-60 seconds)

Pass-Through Sentences

The PRO-MUX-2 also operates as a pass-through device that retransmits all received sentences (that are not filtered out) in real-time as they arrive:

- All standard parametric sentences (starting with \$)
- All encapsulated sentences (starting with !)
- All proprietary sentences (e.g., \$Pxxx,...)

Unused Fields

For generated sentences (**\$MXTXT**, **\$MXALR**): All required fields are populated; optional fields may be unused depending on device configuration and alarm conditions.

For pass-through sentences: Not applicable - all fields are retransmitted without modification.

Proprietary NMEA 0183 / IEC 61162 Sentences transmitted

- **!PARLB** - Actisense proprietary encapsulated binary sentence (transmitted on device restart/power-up (Startup Status) and once per second (System Status, when enabled))

4.1d - Load Requirements as a Listener

The PRO-MUX-2 listener inputs comply with IEC 61162-1 requirements for minimal loading of talker circuits.

Listener Input Characteristics

Electrical Loading

- **Input current:** < 2.0 mA at 2.0V differential (IEC 61162-1 compliant)
- **Input impedance:** ≥ 4 kΩ differential between lines A and B
- **Unit load:** 1 standard unit load per EIA-422/RS-422 specification

Voltage Tolerance

- **Operating range:** 2.0V to 15V differential (absolute value)
- **Maximum voltage withstand:** ±15V between A and B (indefinite, both polarities)
- **Polarity reversal protection:** Full protection, no damage from reversed connections

Electrical Isolation

- **Isolation voltage:** 1000V DC between signal lines (A, B) and device power/ground
- **Fully isolated/floating input:** Full galvanic isolation helps break ground loops and ground potential differences

4.1e - List of Sentences and Data Fields Required as a Listener

Required NMEA 0183 / IEC 61162 received Sentences

No specific sentences are required - the PRO-MUX-2 operates as a universal pass-through multiplexer.

The device accepts all valid NMEA 0183 / IEC 61162-1 compliant sentences:

- Standard parametric sentences (starting with \$)
- Encapsulated sentences (starting with !)
- Proprietary sentences (e.g., \$Pxxx)

The device does not parse or interpret data fields; all sentences are validated (checksum, format) and routed based on user configuration without modification to content.

4.1f - Current Software and Hardware Revision

Hardware Revision

Available in the device web app on the Information page

Format example: **Hardware ID:080104**

08 PRO-MUX-2
01 PCB Revision 1
04 PCB BOM Revision 4

Firmware Revision

Available in the device web app on the Information page

Format example: **Firmware version: 2.145**

4.1g - Electrical Description/Schematic of Listener/Talker Circuits

Listener Circuit Design

- **Differential receiver:** EIA-422/RS-422 compliant receiver integrated circuit
- **Input protection:** Overvoltage protection ($\pm 15V$ continuous), ESD protection, reverse polarity protection
- **Electrical isolation:** 1000V DC galvanic isolation from device ground and power supply
- **Circuit topology:** Balanced differential input, high input impedance, fail-safe biasing

Talker Circuit Design

- **Differential driver:** EIA-422/RS-422 compliant driver integrated circuit
- **Output capability:** Drives 3+ standard unit loads at 4800 baud, 1+ loads at 38400 baud and above
- **Output protection:** Short circuit protection, thermal shutdown protection
- **Circuit topology:** Balanced differential output, low output impedance

Note: Detailed component-level schematics are proprietary. The descriptions above confirm compliance with IEC 61162-1, EIA-422, and ITU-T V.11 specifications.

4.1h - Version and Date of Standard for Which Compliance is Sought

The PRO-MUX-2 is designed and tested for compliance with the following standards:

1. **IEC 61162-1:2016** - Maritime navigation and radiocommunication equipment and systems – Digital interfaces – Part 1: Single talker and multiple listeners (Edition 5.0, 2016-06)
2. **IEC 61162-2:1998** - Maritime navigation and radiocommunication equipment and systems – Digital interfaces – Part 2: Single talker and multiple listeners, high-speed transmission (Edition 2.0, 1998-09)
3. **IEC 61162-1:2024** - Maritime navigation and radiocommunication equipment and systems – Digital interfaces – Part 1: Single talker and multiple listeners (Edition 6.0, 2024)
4. **IEC 61162-2:2024** - Maritime navigation and radiocommunication equipment and systems – Digital interfaces – Part 2: Single talker and multiple listeners, high-speed transmission (Edition 3.0, 2024)

4.1i - List of Supported Baud Rates and Limitations

Supported Baud Rates

Inputs 1-8 and Outputs 1-6

- 4800 bits/s (IEC 61162-1 default)
- 9600 bits/s
- 19200 bits/s
- 38400 bits/s

Serial Port

- 4800 bits/s (IEC 61162-1 default)
- 9600 bits/s
- 19200 bits/s
- 38400 bits/s
- 57600 bits/s
- 115200 bits/s
- 230400 bits/s

Each port can be independently configured for any of its supported baud rates.

Limitations

Automatic baud rate detection: Inputs 1-4 have automatic baud rate detection enabled by default. All other ports require manual baud rate configuration.

Technical Specification

Power Supply	
Input Supply Voltage	9 to 35 V DC
Input Supply Current	220mA max @ 12V DC (all outputs @ full drive into 100 ohm loads)
Input Protection	Continuous reverse polarity, transient overvoltage and ESD protection
Power Indicator	LED, Blue - indicates unit is functioning correctly
Input Supply Connector	Pluggable 2-way screw terminal, 5.08mm pitch (12 to 30 AWG)
NMEA 0183 Port - Listener & Talker	
Number of Listener / Input Ports	8 isolated NMEA 0183 Listeners
Number of Talker / Output Ports	6 isolated NMEA 0183 Talkers
Compatibility	Fully NMEA 0183, RS422 & RS232 compatible. RS485 Listener compatible
Speed / baud rate	4800 to 38400 bps
Talker Output Voltage Drive	>= 2.2V (differential) into 100 ohm
Talker Output Current Drive	20 mA maximum per output
Talker Output Protection	Short circuit and ESD
Talker Data Indicator	LED, Orange (Flashes at data rate)
Listener Input Voltage Tolerance	-15 V to +15 V continuous, -35 V to +35 V short term (< 1 second)
Listener Input Protection	Current limited, overdrive protection to 40 VDC and ESD protection
Listener Data Indicator	LED, Green (Flashes to indicate valid input)
Connectors	Pluggable 2/3-way screw terminals, 5.08mm pitch (12 to 30 AWG)
Serial Port	
Compatibility	RS422 & RS232 compatible. RS485 Listener compatible
Speed / baud rate	4800 to 115200 bps
Output Voltage Drive	>= 2.1V (differential) into 100 ohm
Output Current Drive	20 mA max.
Output Protection	Short circuit and ESD
Input Voltage Tolerance	-15 V to +15 V continuous, -35 V to +35 V short term (< 1 second)
Input Protection	Current limited, overdrive protection to 40 VDC and ESD protection
Data Indicators	LED's: Green = Receive, Orange = Transmit
Connectors	Pluggable 3-way screw terminals, 5.08mm pitch (12 to 30 AWG)
Ethernet Port	
Host Interface	10/100BaseT, automatic polarity detection
Supported Protocols	TCP/IP for configuration and firmware updating
	TCP/IP and UDP for NMEA 0183 comms
Indicators	Green = Link/Activity, Yellow = 100 Mbps
Connector	RJ45
Isolation	
NMEA 0183 Listener	OPTO-Isolated, Hi-Pot tested to 1000V

Intelligent Type Approved NMEA Multiplexer - PRO-MUX-2

NMEA 0183 Talker	Uses IsoDrive™, Hi-Pot tested to 1000V
Serial Port	Uses IsoDrive™, Hi-Pot tested to 1000V
Alarm Relay	Hi-Pot tested to 1000V
Ethernet Port	2kV for 60s
Mode Inputs	
Input Voltage Range	0 to 35V DC
Protection	Transient overvoltage and ESD protection
Connectors	Pluggable 2-way screw terminals, 5.08mm pitch (12 to 30 AWG)
Alarm Output	
Contacts	Common, Normally Open and Normally Closed
Alarm Indicator	LED, Red indicates a valid alarm condition
Contact Ratings	35VAC / 50VDC
Connectors	Pluggable 3-way screw terminals, 5.08mm pitch (12 to 30 AWG)
Mechanical	
Housing Material	316 Stainless Steel
Dimensions	209mm (W) x 129mm (H) x 26.5mm (D)
Weight	540g
Mounting	Bulkhead mount or DIN rail mount (DIN kit 1)
Approvals and Certifications	
EMC	IEC 60945:2002-08, DNVGL-CG-0339:2019 & IACS UR E10 Rev7
Compass Safe Distance	175mm

PRO-MUX-2 Dimensions

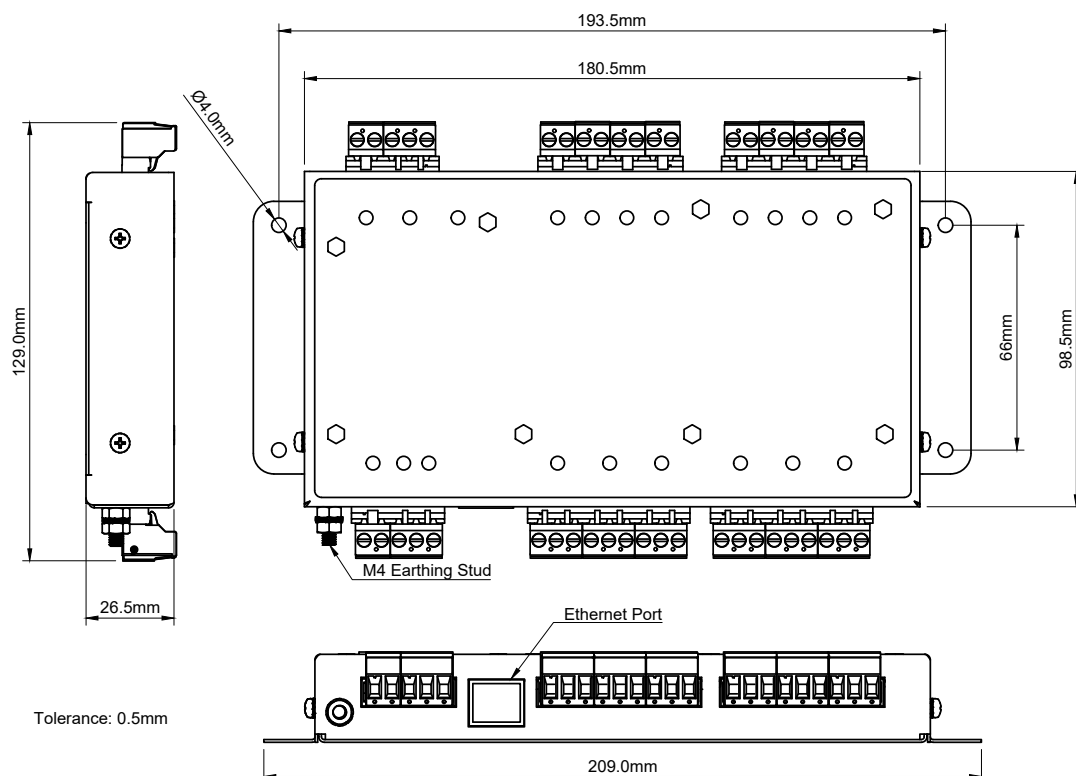

Technical Support and the returns procedure

All installation instructions and any warnings contained in this manual must be followed before contacting Actisense Technical Support. If the troubleshooting guide did not help resolve the problem and an error persists, please contact Actisense Technical Support to help trace the issue before considering the return of the product.

If the Actisense support engineer concludes that the PRO-MUX-2 unit should be returned to Actisense, a 'Return Merchandise Authorisation' (RMA) number will be issued by the support engineer.

The RMA number must be clearly visible on both the external packaging and any documentation returned with the product. Any returns sent without an RMA Number will incur a delay in being processed and a possible charge. Any cables originally supplied with the product are to be included in the returned box.



Active Research Ltd
21 Harwell Road
Poole, Dorset
UK BH17 0GE

Telephone: +44 (0)1202 746682
Email: sales@actisense.com
Web: www.actisense.com